

# Image-based Building Shadow Generation Technique for Virtual Outdoor Scene

Xiaohui Zhang

Masayuki Nakajima

Tokyo Institute of Technology

2-12-1 Ookayama Meguro-ku Tokyo Japan

{zhang, nakajima}@img.cs.titech.ac.jp

## Abstract

Image-based rendering techniques are used by many virtual reality applications, especially in the outdoor scene generation applications. For image-based methods, how to deal with the problem of changing lighting situation, especially daylight is a big problem. Lighting affects image in two respects, shadow and color. Image-based shadow generation problem is one of the very important subjects in image-based methods. In this paper, we concentrate on the building shadow, and propose an approach to solve this image-based building shadow generation problem. The key point of this approach is to abstract a simple geometry model of a building by object matching method, and using this simple model to generate shadow under any novel lighting. In the object matching process, Genetic Algorithms (GA) is employed.

**Keywords:** Shadow generation, Object matching, Genetic algorithms, Virtual outdoor scene

## 1. Introduction

Generating virtual outdoor scene quickly is one of the big requirements in virtual reality. Because of the complexity of 3D model and daylight in outdoor scenery, image-based methods appear charming. Among the outdoor scene, building objects play a very important role, especially in flight, driving simulation systems, virtual traveling system, building design system. In the scenes with building objects, shadow provides strong clues about the shapes relative positions and surface characteristics of

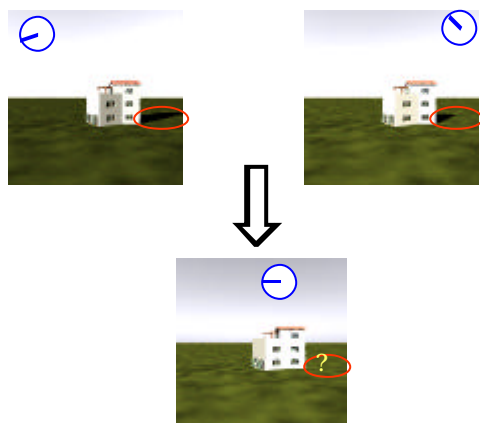

Figure 1 The objective of image-based building shadow generation

the objects. Besides these shadow can also indicate the approximate location, intensity, shape and size of the light source, and even time information.

Shadow is the interaction of object 3D model and the lighting direction. Therefore, without 3D model information, it is hard to generate shadow. Modeling the building from photographs has been studied by Paul Ernest Debevec in [1], the contribution of this paper is to abstract an accurate model and its surface texture from photographs, and rendering it by CG. In order to get the model, the interaction of users is necessary in this work. Besides this work, there are a lot of researches on image-based modeling[2]. The purpose of image-based modeling is to abstract object model as accurate as possible for CG rendering technique. Most of this kind of works need user's interaction. While the aim of this paper is to extract a simple model from several images taken from the same viewpoint but at different times to generate shadow easily and quickly. Therefore different from image-based modeling works, the contribution of this paper is to propose a method to generate shadow under different lighting conditions for image-based rendering and image-based lighting[3]. We call this problem as *Image-based Shadow Generation*.

Though image-based rendering methods have attracted a lot of attention recently, the image-based shadow problem has seldom been studied. This problem can be described as with several building shadow images taken from the same viewpoint but at different times to generate shadow at any arbitrary time, as Figure 1 shows

In our previous work [4], an image-based tree shadow morphing technique is proposed to deal with image-based tree shadow generation problem. The method proposed in [4] employs the abstract geometry model of trees to define the key points of shadows and then uses them as correspondence features. Different from traditional morphing techniques, the key points of new shadows are not determined just by interpolation of the source features and target features, but are calculated on considering the influence of the moving sun. Line segments connected the key points sequentially are used as multiple line pairs and then use the field morphing<sup>[5]</sup> to establish the transformation. The features of tree shadow and building shadow are quite different. Tree shadow is consisted of irregular lines, with rich details and having

holes in it; while building shadow is consisted of regular lines and generally no holes in it. Therefore, though the tree shadow morphing method solve the tree shadow problem very well, it is not suitable for building shadows.

A *shape from shadow silhouette (SFSS)* is used in our previous research[6] to produce building shadows on the ground surface. A 3D model called object shadow shape is reconstructed from several shadow silhouettes by SFSS first. The object shadow shape is a 3D model, which can cast the same shadow on ground surface as the real building shadow. Thus shadow can be generated by projecting this shadow shape easily. Shadow on the ground surface is dealt very well by this method, but for the shadow casting on its own building surface, this method does not work because the 3D shadow shape abstracted is not the exact 3D model of building.

In this paper, we propose a new approach which abstract the simple 3D model of building from several reference images by object matching method. Genetic Algorithms (GAs) is used in the 3D model optimization process. With the simple extracted 3D model, both the shadow on the ground surface or other building surface can be generated easily and quickly.

The paper is partitioned into the following sections. The features of a building and its shadow are described in Section 2. The method of abstracting simple 3D model from shadow images by object matching method is proposed in Section 3. The whole process of image-based shadow generation approach is described in Section 4. The conclusion of this paper and future work are given in Section 5.

## 2. Features of a Building and Its Shadow

For outdoor scene, shadow is generated by the sunlight. Therefore, the sun movement law is necessary to describe briefly.

### 2.1 Solar Geometry

The earth rotates about the sun approximately once every  $365 \frac{1}{4}$  days in an almost circular path. The earth also

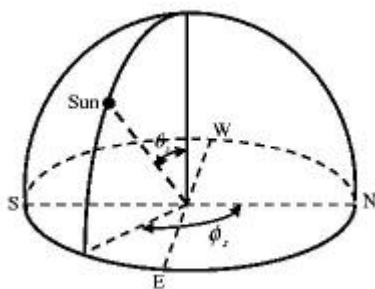

Figure 2 Solar Geometry

spins about its axis every 24 hours giving diurnal variation in solar intensity. The earth's axis of rotation is tilted by 23.45 degree relative to its plane of motion and this causes seasonal variation in sun position. Therefore, the position of the sun in the sky hemisphere, and, as a result, solar intensity, are determined by date, time and global location.

The location of the sun can be given out with the following equation[7]:

$$\cos \theta_s = \sin d \sin L + \cos d \cos L \cos \phi_s \quad (1)$$

$$\sin \theta_s = \frac{\sin d \sin L \cos \phi_s}{\cos L \sin \theta_s}$$

$$\sin d = \cos \left[ (D_s - 1) \frac{180}{182.6} \right] \sin(23.45)$$

$$h = (LST - 12) \times 15$$

where, as shown in figure 2,

$\theta_s$  is the solar zenith,

$\phi_s$  is the solar azimuth,

LST is the local solar time,

$L$  is the latitude, and,

$D_s$  represents the index of the day in one year. It equals to 1 on December 21, and 365 on December 20.

### 2.2 Shadows of Building

Building is a man-made object, its outline is generally regular line, and its 3D model can be represented by blocks. Each block has a small set of scalar parameters which serve to define its size and shape. The block is usually geometry primitive, such as cube, cylinder, hemisphere, cone and so on. By these primitives, a simple model of building can be represented as the model shown in Figure 3.

As described above, several geometry primitives could constitute the basic model of a building. Let's see the shadow of these primitives model. Figure 4 illustrates a point located in  $(X, Y, Z)$ , and its shadow  $(x_s, y_s)$  caused by the sun in direction of  $(\theta_s, \phi_s)$  on surface  $Z = 0$ . Shadow  $(x_s, y_s)$  can be calculated as

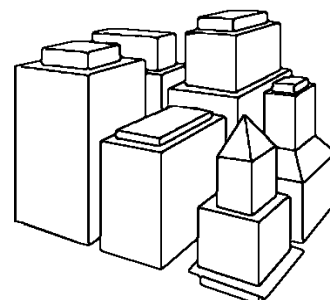

Figure 3 A Building represented by simple 3D

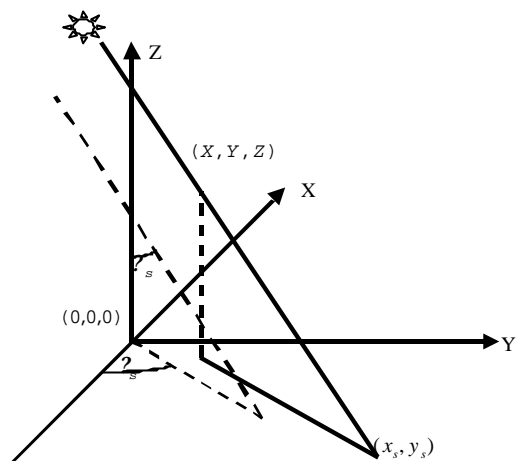

Figure 4 Shadow of a 3D point on surface  $Z = 0$

$$\begin{aligned} x_s &= X \tan \theta_s \cos \phi_s \\ y_s &= Y \tan \theta_s \sin \phi_s \end{aligned} \quad (2)$$

The feature of building decides its shadow has the following features

1. Generally with regular outlines
2. Usually without holes in shadow region

There are mainly three kinds of building shadows. The shadow cast on the ground, the block shade, and the shadow cast on block surface by other blocks. Because of the building shadow features, a simple 3D model of buildings can generate these three kinds of shadows.

The basic idea of this paper is to abstract a simple model consisting of several primitives from several reference shadow images. Having the simple model of a building, its shadow casting on the ground surface or on its own body can be generated quickly. In the following sections, the method of abstracting simple model of building and generating new shadow will be described.

### 3. Abstraction of Simple Building 3D Model

As analyzing in the last section, a simple 3D model of building can give all of the three kinds of shadows, the simple 3D model should be abstracted first. To abstract the simple model, object matching is employed in this paper.

#### 3.1 Object Matching

Object matching is a technique to recover 3D model from 2D images by projecting 3D model to 2D plane and matching with the 2D image. First a initial 3D model is

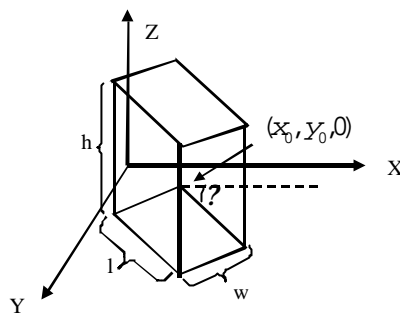

Figure 5 Parameters of a cube

given, then project it to image plane and compare with the reference image. If they are matched, the 3D model is abstracted. If not matched, adjust the 3D model parameters and do the process again. Different from general object matching method, instead of using images taken from different viewpoint, shadow images taken under various sun positions are used instead in this paper

The reference images used in this paper are images taken at different times of a day from the same viewpoint. Camera position, camera parameters, and photographing time are supposed to be known. Thus the shadow images of the initial simple model at each reference time can be produced quickly by CG shadow generation techniques[8]. Compared the generated shadow with the reference shadow images, the error is used to adjust this simple 3D model.

The number and types of primitives constituted the building in the reference images are assigned by user. Though this work is done manually, it would not bring too much burden for users, because for human being it is easy to judge what kind of primitives constituted the building from an image. After appointed how many and what kind of primitives the building consisted, parameters and position of those primitives are extracted by object matching automatically.

The geometry primitives can usually be defined by a few parameters. Take the cube as an example. As Figure 5 shows, a cube on the ground surface can be uniquely specified by only six parameters. These parameters are one corner point coordination  $(x_0, y_0)$ , length  $l$ , width  $w$ , height  $h$ , and the angle  $\theta$  specified the direction of the cube with the direction of X-axis. These six parameters definitely define the cube 3D model.

Though six parameters can defined a box, a pixel in the image plane is a shadow or not is determined by the six parameters. If there are more than one primitives, it will become much more complexity. Therefore, it could be found that the object matching problem here is a hypersurface optimization problem. Along with the object number increasing, the complexity will increase dramatically. For such a problem, general optimization algorithms are not proper. We employ Genetic Algorithms (GAs) in the object matching process in this paper.

### 3.2 Genetic Algorithms

GAs[9] are adaptive methods that may be used to solve search and optimization problems. They are based on the genetic processes of biological organisms. They work with a population of “individuals”, each representing a possible solution to a given problem. Each individual is assigned a “fitness score” according to how good a solution to the problem it is. For example, the fitness score might be the strength/weight ratio for the problem. The highly fit individuals are given opportunities to “reproduce”, by “cross breeding” with other individuals in the population. This produces new individuals as “offspring”, which share some features taken from each “parent”. The least fit members of the population are less likely to get selected for reproduction, and so “die out”. A whole new population of possible solutions is thus produce a new set of individuals. This new generation contains a higher proportion of the characteristics possessed by the good members of the previous generation contains a higher proportion of the characteristics possessed by the good members of the previous generation. In this way, over many generations, good characteristics are spread throughout the population, being mixed and exchanged with other good characteristics as they go. By favoring the mating of the more fit individuals, the most promising areas of the search space are explored. If the GA has been designed well, the population will converge to an optimal solution to the problem. Figure 6 illustrates GA s process.

Take the cube as an example again. The parameters of a cube could be coded as the following string:

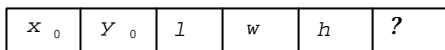

The fitness function of GAs used in this paper is

$$F = \sum_{i=1}^N (R_{match}(i) + R_{unmatch}(i))$$

Here  $R_{match}$  is the ratio of matched shadow area;  $R_{unmatch}$  is the ratio of unmatched shadow;  $N$  is the reference image number.

### 4. Image-based Building Shadow Generation

The whole procedure of our image-based building

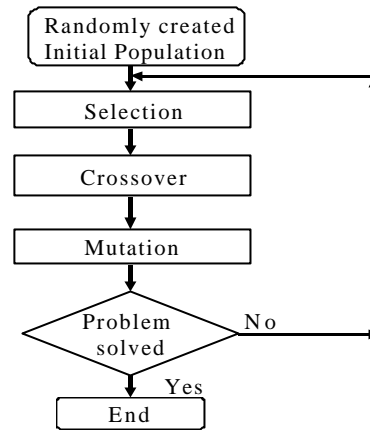

Figure 6 The iteration loop of Basic Genetic Algorithm

shadow generation is shown in Figure 7. There are three steps, *shadow extraction*, *simple model reconstruction*, and *new shadow generation*.

#### 4.1 Shadow Extraction

Shadows are first abstracted from reference image. In this paper, only building shadow of an outdoor scene is considered. For outdoor scene, the sun is the only light source which can cause shadow, in addition, since daylight can be treated as white light, so the shadow caused by it, could be thought as black color.

Since skylight can be thought as emitting from sky dome that surrounds the earth, we can assume shadows are caused only by direct sunlight. The illuminance of a clear day is greater than that of an overcast day. Consequently, the intensity of pixel in a clear day must be greater than that of its corresponding pixel in an overcast day, except for the shadow region. If the intensity of a pixel in a clear day is less than that of an overcast day image, this pixel must fall into the shadow region. In this way, shadow region can be discriminated simply.

Figure 8(b) shows the extracted shadow silhouettes from the reference images of a box shown in Figure 8(a). The reference images Figure 8(a) are generated by Radiance[10], and the camera parameters and view

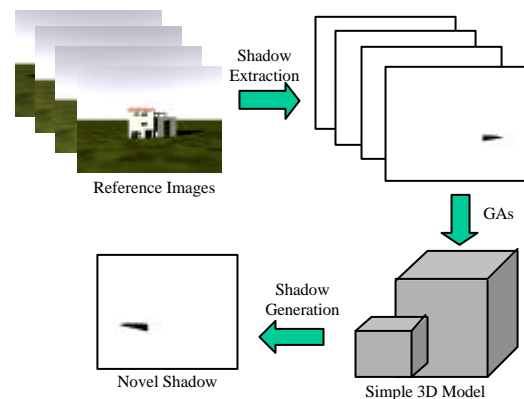

Figure 7 The flow chart of image-based building shadow generation

position are known.

## 4.2 Simple Model Reconstruction

The number and type of primitives, which construct the basic geometry model of building, are assigned by user manually first. Then by using object matching method, the simple 3D model of buildings are optimized by GAs.

Table 1 GA parameters

Population Number	500
Crossover Probability	0.8
Mutation Probability	0.1
Generation Number	54

The speed of optimization by GAs is determined by the population number, crossover probability, mutation probability, and the coding length. Table 1 lists the GAs parameters we used to extract the simple 3D model of a box shown in Figure 8(a). The terminal condition is the fitness of the best individual reaches 0.9. The extracted model parameters are shown in table 2, its view on the

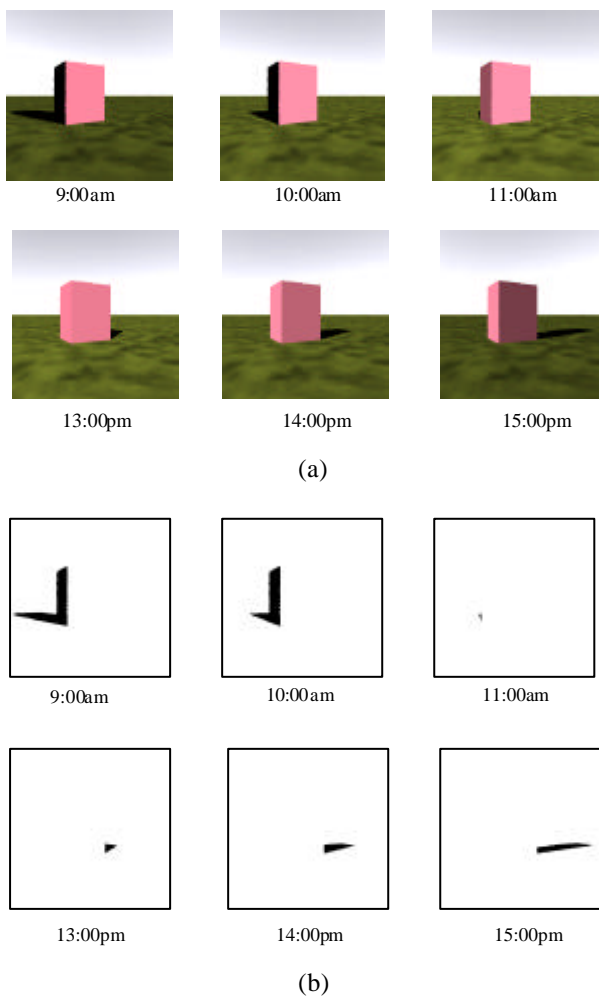

Figure 8 (a) Reference images of a box; (b) Shadow images

image plane is shown in Figure 9(a).

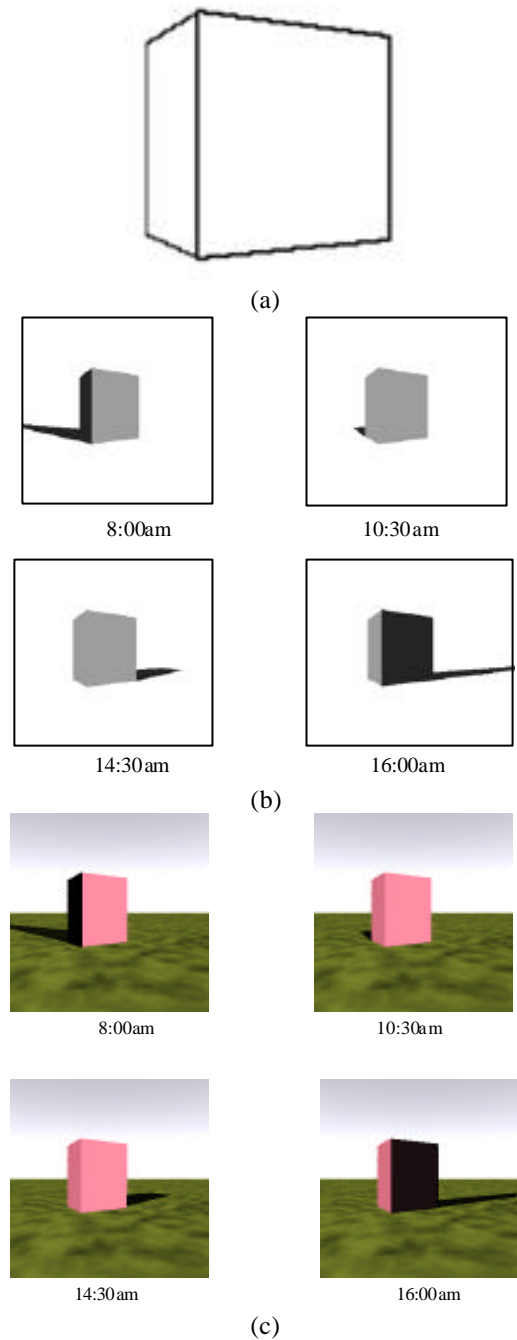

Figure 9 (a) Abstracted box model; (b) Generated shadow by the abstracted box model; (c) New generated shadow combined with other scene

Though the model abstraction process using GAs is a little time consuming, it is an offline process, and would not affect the rendering speed.

## 4.3 New Shadow Generation

Finally, after the simple model of a building being extracted, new shadow under any sun position can be generated quickly by CG shadow generation method.

From table 2, we can realize that the extracted parameters are a little different from the original one, moreover the model extracted is only a simple model of building, and

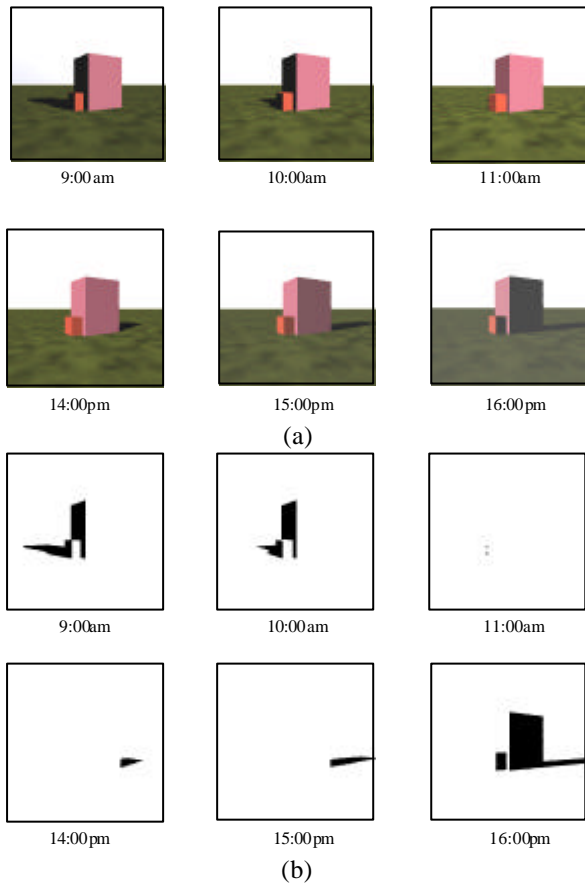

Figure 10 (a) Reference images of two boxes joined by common side; (b) Shadow images

therefore shadow generated by this simple extracted model maybe a little shift from the real shadow. For the shadow on the ground, a little shift could not affect the visual effect, but for the building self-shadow, even small shift will deteriorate the quality of the synthesized image. To overcome this problem, the following approach is proposed.

In order to let the new building self shadow align with the outline of building surface, the outline of the building is extracted by canny edge detect method [11]. Then if there is a building surface line matches the line of new self shadow, take the building surface line to replace the new self shadow line. If there is no such build line matched, keep the new self shadow line unchanged.

Table 2 Abstracted parameters

	$x_0$	$Y_0$	$l$	$w$	$h$	$?$
Abstracted parameters	0.12	0.02	9.97	8.10	13.03	29.7
Real parameters	0	0	10	8	13	30

Combine the new shadow with the original scene, the image-based building shadow generation problem has been solved. Figure 9(b) shows the new shadow generated by our approach, Figure 9(c) are new images by combining the new generated shadow with other scene. The result illustrates that the shadow on ground and self-shadow can be generated correctly. The shadows at 8:00am and 16:00pm are generated correctly, though they are the shadows beyond the range of reference images. This means that new shadow image at the time beyond the reference images time arrange can also be generated correctly, while this is can not be solved by previous work [6].

Figure 10 is another example of two boxes standing on the ground surface  $Z=0$ , and joined by common side. Figure 10(a) shows the reference images, Figure 10(b) shows the extracted shadows. The parameters which define these two connected boxes are described in Figure 11.  $l_1$ . Here  $w_1, h_1, l_2, w_2, h_2$  are the length, width and height of box1 and box2 respectively. Here assume the two boxes have the same direction, and specified by angle  $?$ . The position of box1 and box2 is specified by a point  $(x, y)$ , which located on the common line of these two boxes, and the two ratio parameters as shown in

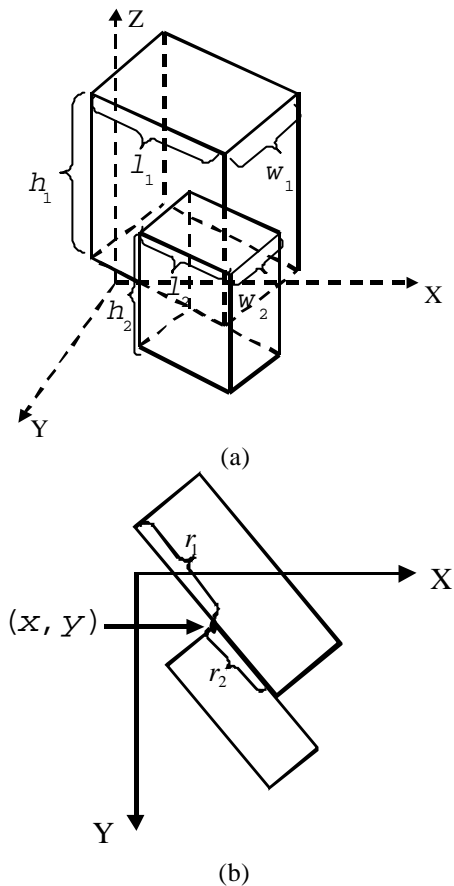

Figure 11 Parameters of two boxes standing on the ground surface and joined by common side. (a) side view; (b) vertical view

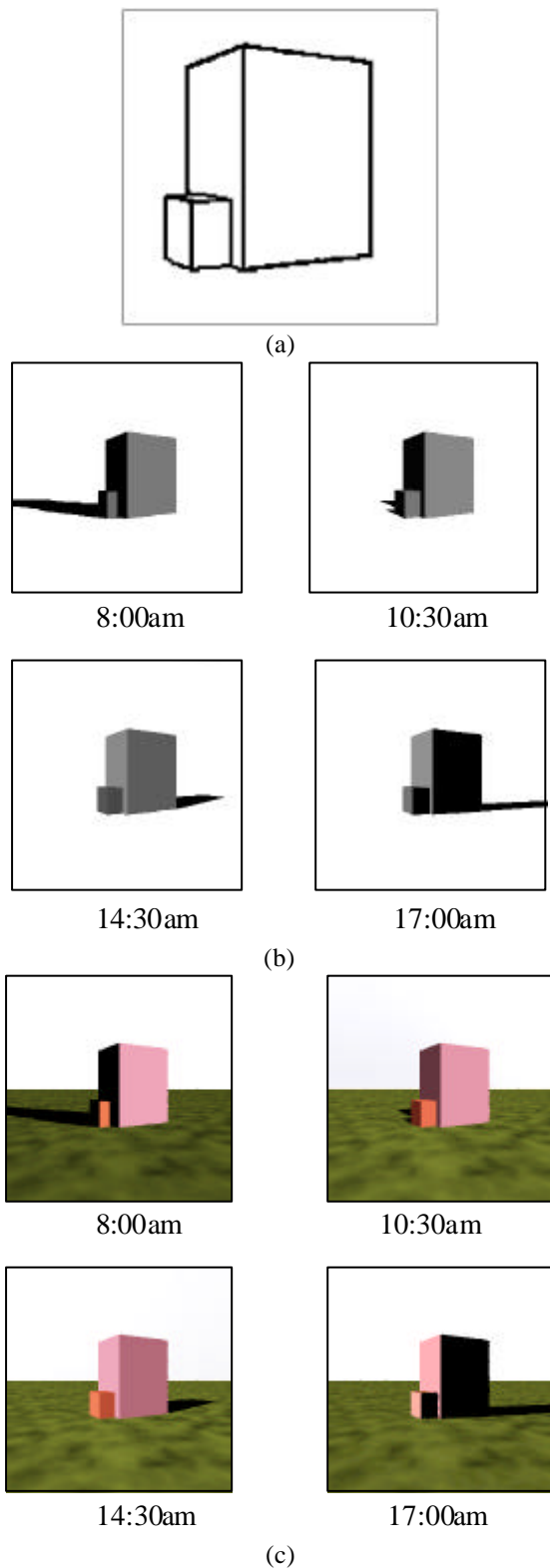

Figure 12 (a) Extracted model; (b) Generated shadow by the abstracted box model; (c) New generated shadow combined with other scene

Figure 11(b).

Figure 12(a) is the simple model extracted by our method. The resulted new shadows are shown in Figure 12(b). The results of combined with other scene are shown in

Figure 12(c). The new shadow image of 7:30am and 16:30 in Figure 12(b) shows very clear that the shadow on the small box cast by the bigger box is generated. The kind of shadow also appears on the new shadow image of 16:30pm in Figure 12(b). It demonstrates that the shadow cast by other block is well solved.

For this example, the reference images which taken at time 9:00am, 10:00am, and 16:00pm are very important for extract the smaller box because these shadow images include the shadow information of the smaller box. If there is no information of the small box, the model abstracted by GAs would not be correct. Only using one shadow references image, there will be many specified 3D model, which can generate the shadow. For a box, the minimum shadow reference shadows should include the information, which uniquely determine its height, length, and width. For the relationship between the reference number of shadow image and the correctness of abstracted model are needed further study.

## 5. Conclusion

The image-based shadow generation problem is a very important problem of image-based outdoor scene generation in virtual reality. This paper as a beginning work of image-based shadow generation, studies the building shadow features. According the features that general buildings are constructed by several simple primitives, we propose an approach to build a very simple building model from its shadow reference images by object matching method. Since the parameter optimization is a hyper surface optimization problem, GAs is employed in the object matching process. Having the simple model of building, its shadow caused by the sun at time can be generated very quickly.

As this paper is only a beginning, there are a lot of problem should be solved. The experiments are only the very simple model, in the future, we will exam this approach to the complex building scene. Besides, the user interface and how to improve the GAs speed will also be considered.

## Reference

- 1 Paul Ernest Debevec, Modeling and Rendering Architecture from Photographs, doctor thesis of University of California at Berkeley. 1996
- 2 Paul Debevec, What Image Image-based Modeling and Rendering, and What Is Image-based Lighting, SIGGRAPH'99, course39.
- 3 Paul Debevec, Image-based Lighting, [http://www.ee.oulu.fi/~kapu/cg\\_course/lectures/b-image-based-lighting.pdf](http://www.ee.oulu.fi/~kapu/cg_course/lectures/b-image-based-lighting.pdf)
- 4 Xiaohui ZHANG and Masayuki Nakajima, Image-based Tree Shadow Morphing Technique, The

- Journal of the Institute of Image Electronics Engineers of Japan, Vol.28, No.5, 2000.
- 5 T. Beier and S. Neely, Feature-Based Image Metamorphosis, Computer Graphics(Proc. Siggraph 92), Vol. 26, No. 2, pp. 35-42, 1992
  - 6 Xiaohui ZHANG and Masayuki Nakajima, A study on Image-based Scene Modeling and Rendering Part IV—Building Shadow Generation by Shape from Shadow Silhouette, Proceedings of the 2000 Information and Systems Society Conference of IEICE, D-12-63
  - 7 D.Rapp, "Solar Energy", Prentice-Hall, 1981.
  - 8 Andre Woo, Pierre Poulin, and Alain Fournier, A Survey of Shadow Algorithms, IEE Computer Graphics and Applications, vol. 10, no. 6, November 1990
  - 9 D.E.Goldberg, Genetic Algorithms in search, optimization and machine learning, Addison-Wesley, 1989.
  - 10 G. Ward, "The RADIANCE Lighting Simulation and Rendering System", SIGGRAPH'94 Proceedings", pp.459-472, 1994
  - 11 Canny, J. (1986). A computational approach to edge detection. PAMI, 8(6), pp.679-698.